



Tunnel Vent Shafts

Hawkins Steel Ltd were awarded the contract to design, fabricate and install five vent shaft support structures in Catesby Tunnel. These structures were installed within the tunnel development and are required to create a seal at the bottom of each vent shaft. It was a fundamental requirement of the client that the test track was protected from water ingress to avoid possible debris falling onto the track from the vent shafts above.

The top of the structures were waterproofed with a liquid product applied on top and all masonry mortar joints sealed so that a structural foam could be injected to fill a 100mm polo shaped void created within the structure. This provides the watertight seal to the vent shaft wall and our structure.

This has been a challenging project that has been a team effort in both the design and construction of the structures, along with the sequencing of the install and the waterproofing and sealing of them.

This is another great example of Hawkins at its very best when departments collaborate to create a workable solution. A special mention has to go to Dave Elliot and James Morrison, who has been instrumental in the successful delivery of this project, along with MR Site Services fantastic support in the waterproofing process.

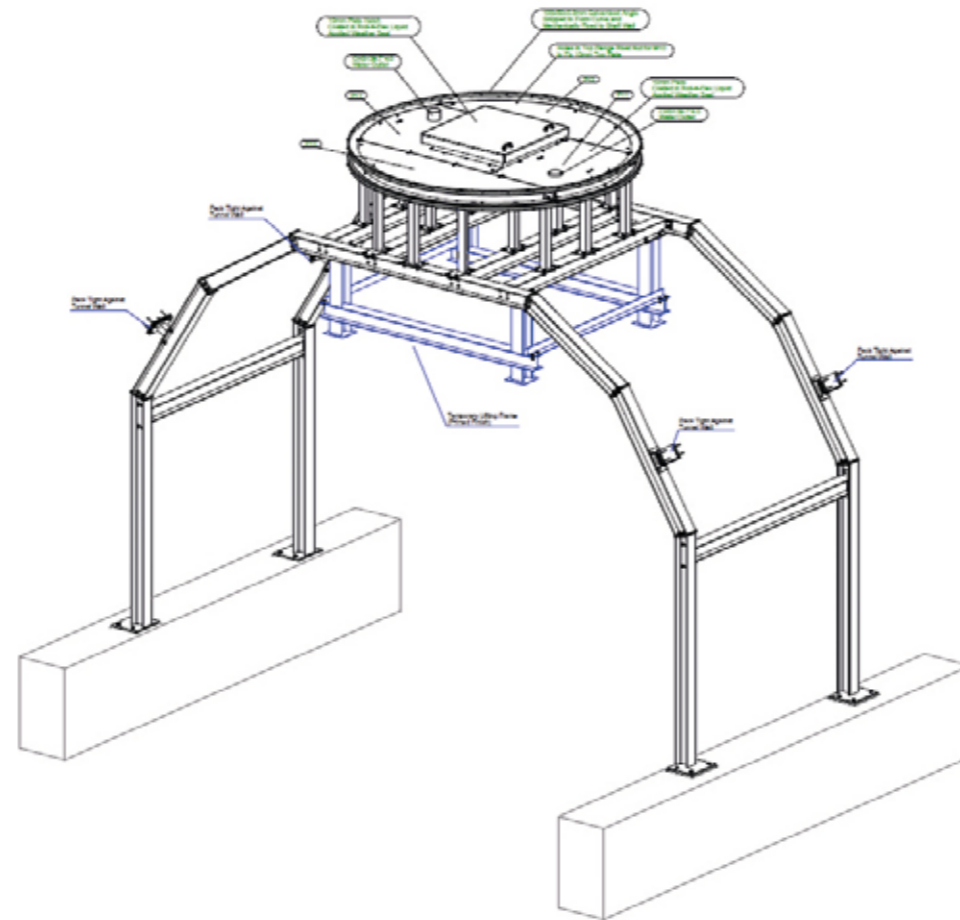

CLIENT	Stepnell Ltd
LOCATION	Daventry
TIMESCALE	8 Weeks
VALUE	Undisclosed